

EXISTING TYPICAL SECTION

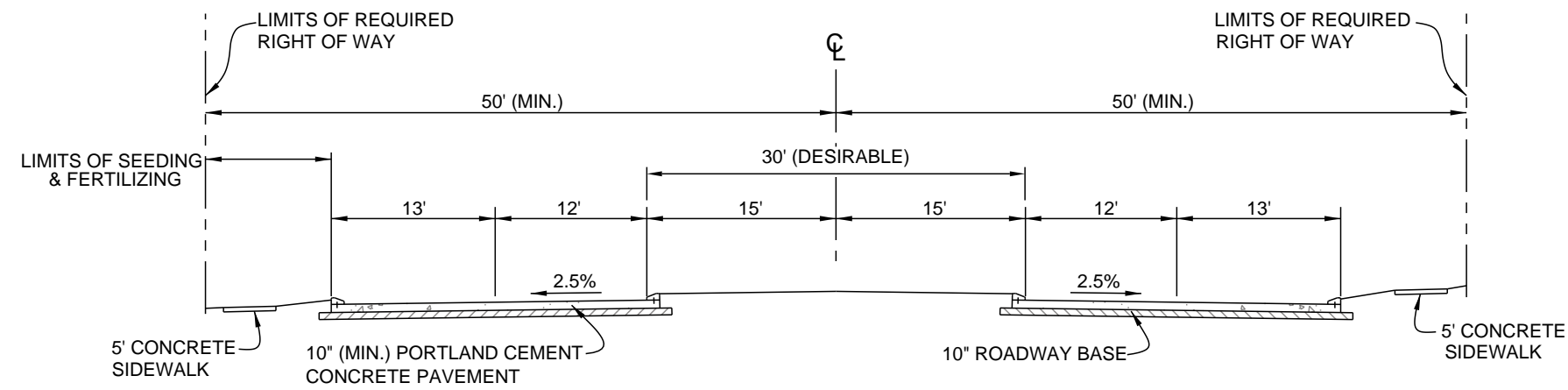

PROPOSED TYPICAL SECTION



In association with:
 PBS&J
 GOTECH, Inc.
 Neel-Schaffer, Inc.
 Compliance Consultants, Inc.
 Jones Walker, LLP
 John C. Doiron
 MAI Appraisal Services
 Rampart Resources
 SSA Consultants, LLC

Project:
 Old Hammond
 Highway-Seg 2 (1,135'
 East of Millerville Road
 to 850' West of
 O'Neal Lane)

Exhibit A

Date: January 7, 2008
 Project Number: 25041.00
 Drawn By: GB
 Checked By: BD

